

Electric Compliance

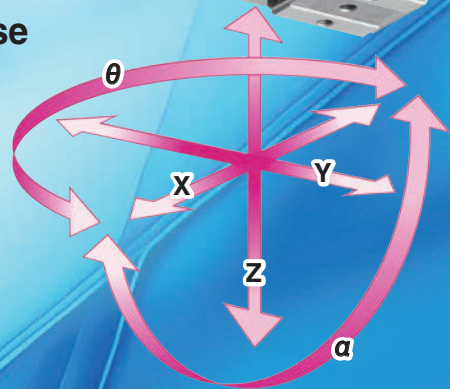

- Industry's First* Airless Type (*In-house research)
- 2 Types: Parallel type and Swing type
- High rigidity and withstand load capacity
Parallel type can be used as a press fitting base
- 2 size variations
□ 52 mm [2.047 in.], □ 70 mm [2.756 in.]



□ 52 mm [2.047 in.]



□ 70 mm [2.756 in.]

Electric Compliance ECPL

- **Industry's First* Airless Type** (*In-house research)
- **Power saving: No need for power after locking**
- **Easy controls**
 - Control by turning ON and OFF, same as solenoid valves.
 - Use Operation check (EAK) to manually turn ON and OFF.
- **Electric Auto Hand Changer (EMJ) can be directly mounted**
- **2 size variations** □ 52 mm [2.047 in.], □ 70 mm [2.756 in.]
2 Types: Parallel type and Swing type



Operation check (EAK)



□ 52 mm [2.047 in.]



□ 70 mm [2.756 in.]

Parallel type

- In addition to being optimum for automatically aligning errors for workpiece insertion, the Parallel type can be used as a press fitting bases.
- Optimum for robot hands
- Parallel type movement directions: X, Y, θ
- No centripetal force can be selected (Option: -N)

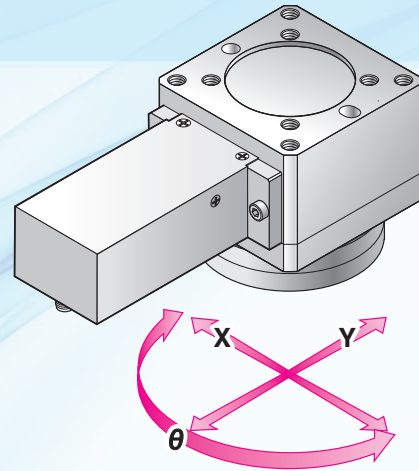

● Top view



● Front view



● Bottom view

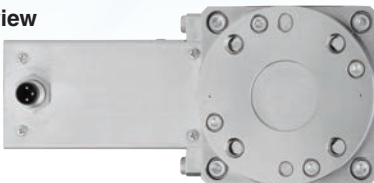

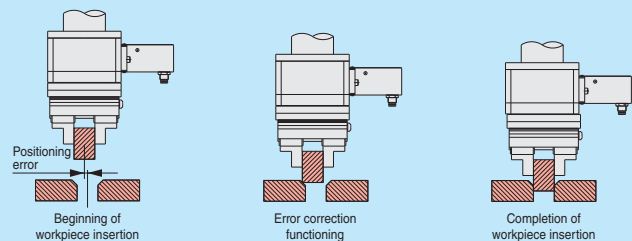

Explanation of operation



- When locked: Plate is held at the center position.
- When unlocked: Corrects positioning errors.
When there is centripetal force, then the center position is maintained by centripetal force.

Variations

Main unit 52 mm [2.047 in.]		Blank: With centripetal force	-N: Without centripetal force
Main unit 70 mm [2.756 in.]		Blank: With centripetal force	-N: Without centripetal force

Swing type

- Optimum for automatically aligning errors for workpiece insertion.
- Optimum for robot hands
- Swing type movement directions: X, Y, Z, θ , α
- No centripetal force can be selected (Option: -N)

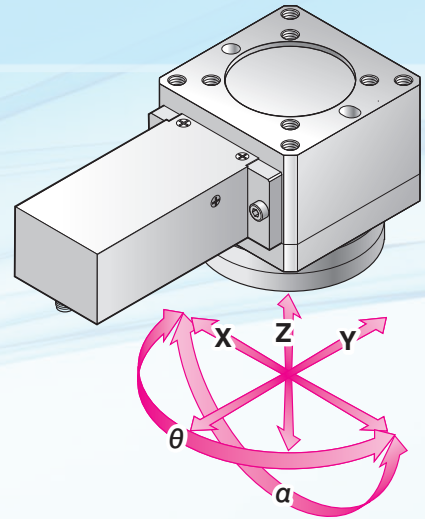

● Top view

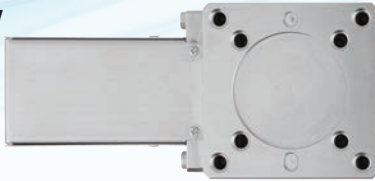

● Front view



● Bottom view

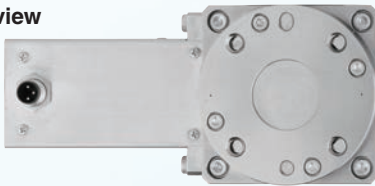

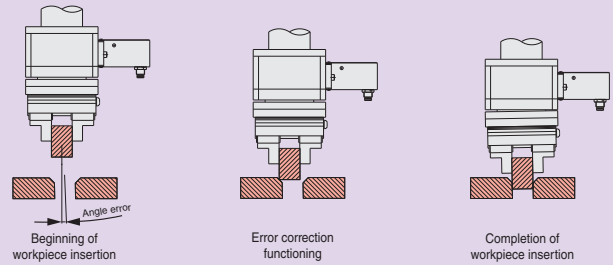

Explanation of operation



- When locked: Plate is held at the center position.
- When unlocked: Corrects positioning errors.
When there is centripetal force, then the center position is maintained by centripetal force.

Variations



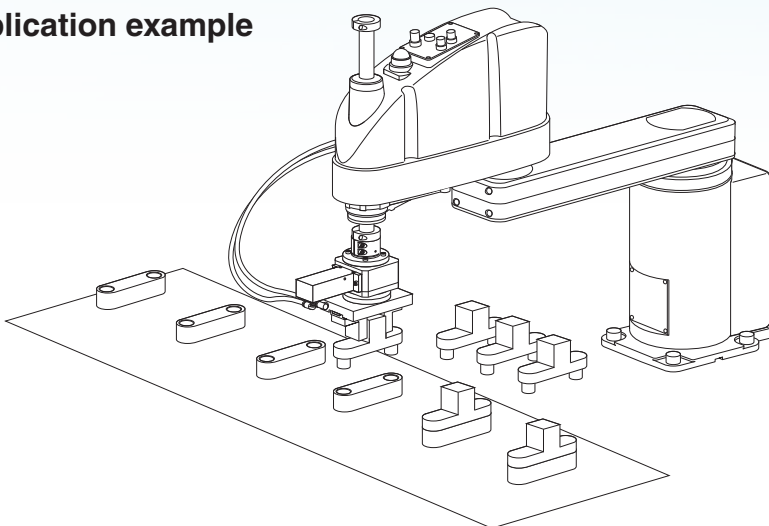

<p>Main unit 52 mm [2.047 in.]</p> 	Blank: With centripetal force	-N: Without centripetal force
<p>Main unit 70 mm [2.756 in.]</p> 	Blank: With centripetal force	-N: Without centripetal force

Application example



Before selecting and using the product, please read all the Safety Precautions carefully to ensure proper product use. The Safety Precautions shown below are to help you use the product safely and correctly, and to prevent injury or damage to you, other people, and assets. Be sure to comply with JIS B 8433 (safety standards for industrial robots).

The directions are ranked according to degree of potential danger or damage: “DANGER”, “WARNING”, “CAUTION”, and “ATTENTION”.

 DANGER	Indicates situations that can be clearly predicted as dangerous. If the noted danger is not avoided, it could result in death or serious injury. It could also result in damage or destruction of assets.
 WARNING	Indicates situations that, while not immediately dangerous, could become dangerous. Death or serious injury may result if the situation is not avoided. It could also result in damage or destruction of assets.
 CAUTION	Indicates situations that, while not immediately dangerous, could become dangerous. Minor or semi-serious injury may result if the situation is not avoided. It could also result in damage or destruction of assets.
 ATTENTION	While there is no chance of injury, these points should be observed for appropriate use of the product.

- **This product was designed and manufactured for use in general industrial machinery.**
- In the selection and handling of the equipment, the system designer or other person with fully adequate knowledge and experience should always read the Safety Precautions, Catalog, Owner's Manual and other information before commencing operation. Making mistakes in handling is dangerous.
- The customer is responsible for verifying and determining the compatibility of the product with the customer's system.
- After reading the "Catalogs", "Owner's Manual", and other information, always store them in a location that allows easy availability for reference to users of this product.
- If transferring or lending the product to another person, always attach the "Catalog", Owner's Manual, etc., to the product where they are easily visible, to ensure that the new user can use the product safely and properly.
- The danger, warning, and caution items listed under these Safety Precautions do not cover all possible contingencies. Read the catalog and Owner's Manual carefully, and always keep safety first.

 **DANGER**

- Do not use the product for the purposes listed below:
 1. Medical equipment related to maintenance or management of human lives or bodies
 2. Mechanical devices or equipment designed for the purpose of moving or transporting people
 3. Critical safety components in mechanical devices
 This product has not been planned or designed for purposes that require advanced levels of safety. It could cause injury to human life.
- Do not use the product in locations with or near dangerous substances such as flammable or ignitable substances. It could ignite or cause a fire.
- Keep away from the operating range of the equipment while the product is operating or in an operational state. Also, do not make any adjustments to internal or attached mechanisms while the product is operating. The actuator can move suddenly, possibly resulting in injury.
- Persons using a pacemaker or other similar medical devices should maintain a distance of at least one meter [3.280 ft] away from the product. The magnetic field of the strong magnet built into the product may cause the pacemaker to malfunction.
- When mounting the product, always firmly support and secure it (including the workpiece). The product may fall over, be dropped, or operate abnormally and cause a personal injury.
- Never attempt to modify the product. Doing so creates the risk of injury, electric shock, fire, etc. due to abnormal operations.
- Never attempt inappropriate disassembly or assembly of the product relating to its basic configuration, or its performance or functions. Doing so creates the risk of injury, electric shock, fire, etc.
- Do not splash water on the product. Spraying it with water, washing it, or using it under water could result in abnormal operation leading to injury, electric shock, fire, etc.

 **WARNING**

- Do not use the actuator as a device to absorb the shock or vibration of machinery. It could break and possibly result in injury or in damage to the machinery.
- Do not use the product in excess of its specification range. Use in excess of its specification range could result in product breakdown, loss of function, or damage. It could also drastically reduce operating life.

- Design safety circuits and devices to prevent damage to machinery and personal injury when the machine is shut down due to an emergency stop or system abnormalities, such as an electrical power failure.
- Provide adequate shielding measures for use in the locations described below. Failure to install such measures may cause a malfunction resulting in damage to the equipment or an injury.
 1. Locations where high electric currents or strong magnetic fields are generated
 2. Locations where static electricity or other types of noise are generated
 3. Locations where there is the possibility of radioactivity
- Before installing the product to your equipment, make sure that the installation, wiring, and operating commands are correct and suitable. If you use it without confirming these things, it could contact moving parts and result in injury or in damage to mechanical equipment.
- Before supplying electricity to start operating the product, be sure to do a safety check of the operating range of the equipment. Unintentional supply of electricity may cause electric shock or injury due to contact with moving parts.
- Do not touch terminals or switches while the power is turned on. There is a risk of electric shock or abnormal operation.
- Do not allow cables or other cords to be damaged. Allowing cords to be damaged, bent excessively, pulled, rolled up, placed under heavy objects, or squeezed between two objects may cause current leaks or defective continuity that can lead to fire, electric shock, or abnormal operation.
- If you ever notice abnormal noise or abnormally high vibration, immediately stop operation. Continued use under such conditions may result in damage to the product, abnormal operation due to damage, or runaway operation, etc.
- Do not throw the product into fire. The product could explode and/or release toxic gases.
- Do not sit on the product, place your foot on it, or place other objects on it. Doing so could cause an accidental fall or the product toppling or dropping, which may result in personal injury or damage to the product that results in malfunction or runaway operation.
- Before any maintenance inspections, repairs, replacement, or other similar work, always completely cut off the electric supply.
- Use the product within the recommended load.

 **CAUTION**

- Do not use the product in locations that are subject to direct sunlight (ultraviolet radiation), in locations with dust, salt, or iron particles, or in locations subject to extreme humidity, or in atmospheres that include organic solvents, phosphate ester based hydraulic oil, sulfur dioxide gas, chlorine gas, acids, etc. Such uses could lead to loss of functions within a short period, sudden degradation in performance, or reduced operating life.
- Do not use the product in environments where there is corrosive gas, flammable gas, flammable liquid, etc. There is a risk that the formation of rust could cause strength to deteriorate, or the motor to catch fire or explode.
- Use only the controller specified for the product. Using an unspecified one so may cause product malfunction or runaway operation.
- Set up the main unit and controller in a location where there is little dirt and dust. Setting it up in a location where there are large amounts of dirt and dust creates the risk of malfunction.
- Do not set up the product in a location subject to strong vibration (greater than 4.9 m/s² [0.5 G]). Strong vibration creates the risk of malfunction.
- When installing the product, leave room for adequate working space around it. Failure to do so will make it more difficult to conduct daily inspections or maintenance, which could eventually lead to system shutdown or damage to the product.
- Do not bring any magnetic media or memory within one meter [3.280 ft] of the product. Doing so creates the risk of damage to data on the magnetic media due to magnetism.
- Do not scratch, dent, or deform the actuator by climbing on the product, using it as a step, or placing objects on top of it. It could damage or break the product, which could result in operation shutdown or degraded performance.
- Always be sure to post a "Work in Progress" sign during installation, adjustment, or other operations, to avoid unintended supply of electric power, etc. Unintended supply of power may cause electric shock or sudden actuator operation, creating the risk of personal injury.
- Never conduct an insulation resistance test or dielectric strength test on the controller.
- Do not apply excess force to the base of the main unit cables.
- Do not apply excess force to the connectors of the main unit cables.

 **ATTENTION**

- When considering the possibility of using this product in situations or environments not specifically noted in the Catalog or Owner's Manual, or in applications where safety is an important requirement such as in an airplane facility, combustion equipment, leisure equipment, safety equipment, and other places where human life or assets may be greatly affected, take adequate safety precautions such as an application with enough margins for ratings and performance or failsafe measure.
Be sure to consult us about such applications.
- Use a protective cover, etc., to ensure that human bodies do not come into direct contact with the operating portion of mechanical devices, etc.
- Do not set up controls in a way that would cause workpieces to fall during power failures.
Use control measures such that they prevent the workpieces, etc., from falling during a power failure or emergency stop of the mechanical devices.
- Check the Owner's Manual while you install and wire the product.
- When handling the product, wear protective gloves, safety glasses, safety shoes, etc., as necessary to remain safe.
- Always conduct daily inspections, and confirm that all requisite system functions are satisfied, to prevent accidents from happening.
- When the product can no longer be used, or is no longer necessary, dispose of it appropriately as industrial waste.
- For inquiries about the product, consult your nearest Koganei sales office or Koganei Overseas Department. The addresses and telephone numbers are shown on the back cover of this catalog.

 **Other**

- Always observe the following items.
 1. When using this product in a system, always use genuine Koganei parts or compatible parts (recommended parts).
When conducting maintenance and repairs, always use genuine Koganei parts or compatible parts (recommended parts).
Always observe the required methods and procedures.
 2. Never inappropriately disassemble or modify the product in relation to its basic construction, performance, or functions.

Koganei cannot be responsible if these items are not properly observed.

Warranty and General Disclaimer

1. **Warranty Period**
The warranty period for Koganei products is 1 year from the date of delivery.
*However, some products have a 2-year warranty; contact your nearest Koganei sales office or the Koganei overseas department for details.
2. **Scope of Warranty and General Disclaimer**
 - (1) When a product purchased from Koganei or from an authorized Koganei distributor or agent malfunctions during the warranty period in a way that is attributable to Koganei's responsibility, Koganei will repair or replace the product free of charge. Even if a product is still within the warranty period, its durability is determined by its operation cycles and other factors. Contact your nearest Koganei sales office or the Koganei overseas department for details.
 - (2) The Koganei product warranty covers individual products. Therefore, Koganei is not responsible for incidental losses (repair of this product, various expenses required for replacement, etc.) caused by breakdown, loss of function, or loss of performance of Koganei products.
 - (3) Koganei is not responsible for any losses or for any damages to other machinery caused by breakdown, loss of function, or loss of performance of Koganei products.
 - (4) Koganei is not responsible for any losses due to use or storage of the product in a way that is outside of the product specifications prescribed in Koganei catalogs and instruction manuals, and/or due to actions that violate the mounting, installation, adjustment, maintenance or other safety precautions.
 - (5) Koganei is not responsible for any losses caused by breakdown of the product due to factors outside the responsibility of Koganei, including but not limited to fire, natural disaster, the actions of third parties, and intentional actions or errors by the purchaser.



General precautions

Environment

1. Avoid use in locations where there is the chance of water droplets, oil droplets, or other liquids getting onto the main unit, controller, or operation checker and where there are large amounts of dust.
2. Do not use the product in environments which may be corrosive.
3. Avoid locations subject to strong vibration and/or impact (greater than 4.9 m/s^2 [0.5 G]).

Wiring

1. Secure the cables so there are no twisting, pulling, bending, or other loads on the connectors of the main unit and controller. The relay cable's fixed bending radius is 18 mm [0.709 in.] or greater, and the moving bending radius is 36 mm [1.417 in.] or greater.
2. The connectors on the main unit may become easier to rotate, depending on the storage and usage environments (high humidity environment). Fix the cables so they do not interfere with peripheral devices while the product is operating.
3. The direction of the cable can be changed by loosening the hex nut that secures the connector on the Electric Compliance. The direction of the cable can be put within the range in the following diagram. Hold the cable as you tighten the hex nut. Tightening torque of the hex nut is up to $1 \text{ N}\cdot\text{m}$ [8.851 in·lbf].

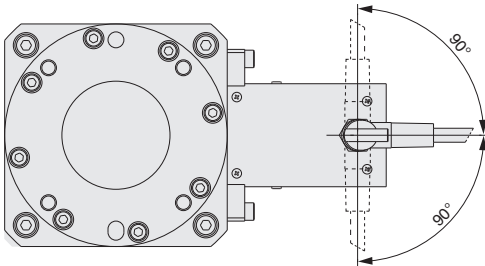

Handling

1. Confirm that there is no electric power connected to the product before starting maintenance work.
2. Displacement should not exceed the allowed range of movement in any direction. It could result in damaged or broken a product that results in operation shutdown or degraded performance.
3. To lock or unlock the function for error correction (compliance), switch it by the controller. Unlock it when inserting or pushing and lock it when moving. Also, at the moving end, stop it as smoothly as possible. Sudden stops may cause the lock to disengage, and reduce the centripetal accuracy.
4. Use within the range for the maximum load capacity. Using this unit while exceeding the maximum load capacity may cause wear or degradation to the sliding parts.
5. The values for the allowable loads are static loads. Treat it as a temporary load in a stationary state. Ensure that there are sufficient allowances if the unit is subjected to impacts. When press fitting, use a load of 1/10 or less of the value for the allowable load.
6. The value for the allowable load is a static load. Treat it as a temporary load in a stationary state. Ensure that there are sufficient allowances if the unit is subjected to impacts. When press fitting, use a load of 1/10 or less of the value for the allowable load. The mounted load should be less than the maximum load capacity.
7. The center position when locked to the plate and the center position when unlocked may be misaligned.
8. Mount the product so that the center of gravity of the mounted load falls within the plate's outer diameter, and do not operate with an overhanging load. Doing so may cause wear or degradation to the sliding parts.
9. Products that do not have centripetal force (-N), the retaining force and the retaining moment are the same as the values indicated.
10. When a robot or other actuator performs a linear or rotational movement, an excessive moment may be generated due to the inertial force of the mounted load. Ensure sufficient allowances even within the range of holding force and holding moment.
11. The stepping motor could increase temperature under certain operating conditions. Use the Electric Hand within the operating temperature range. Use of the Electric Hand in conditions exceeding the operation limits could result in damage or in burning of the motor.
12. In some operating conditions, the operating sound may increase, but this is not a fault.

Installing

1. Use it so it is in a horizontal position when it is unlocked. The mounting surface should be flat. If the cylinder twists or bends when mounted, not only will it be inaccurate, but there may be defective operations.
2. Note that if the product's mounting surface is scratched or dented it can adversely affect flatness.
3. Be sure that the unit and the mounting bolts are strong enough.
4. In cases where loosening of screws due to impact and/or vibration may be a factor, consider looseness prevention measures. Be careful that adhesive spreads out evenly. If the adhesive gets into the product, it may cause defective operation.
5. Be careful that error correction (compliance) is not obstructed by piping and wiring when mounting hands, etc., to the mounting surface.
6. Install the controller so there is adequate space around it (20 mm [0.787 in] or more) with good ventilation.
7. For the controller's ground terminal, use the power cable's F.G. wire.

Handling Instructions and Precautions

Tightening torque

● Mounting a workpiece

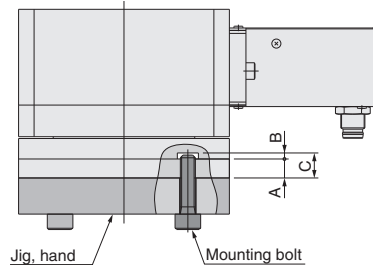

Type	Model	Bolt	Maximum tightening torque (N·m) [in·lbf]	A (mm [in.])	B (mm [in.])	C (mm [in.])
Parallel type	ECPL52F	M5×0.8	3 [26.553]	5.2 [0.205]	1.5 [0.059]	6.7 [0.264]
	ECPL70F	M5×0.8	3 [26.553]	6.3 [0.248]	1.5 [0.059]	7.8 [0.307]
Swing type	ECPL52S	M5×0.8	3 [26.553]	6.7 [0.264]	1.5 [0.059]	8.2 [0.323]
	ECPL70S	M5×0.8	3 [26.553]	7.8 [0.307]	1.5 [0.059]	9.3 [0.366]

● Mounting the main unit

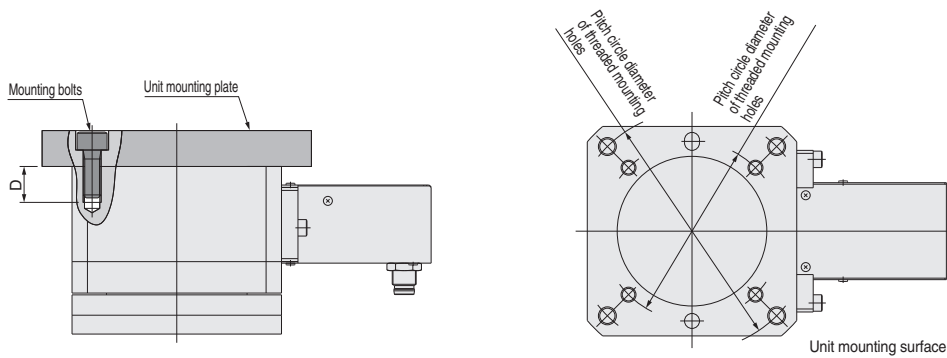

Type	Model	Pitch circle diameter of threaded mounting holes (mm [in.])	Bolt	Maximum tightening torque (N·m) [in·lbf]	D (mm [in.])
Parallel type	ECPL52F	42 [1.654]	M5×0.8	3 [26.553]	7 [0.276]
		60 [2.362]	M5×0.8	3 [26.553]	10 [0.394]
	ECPL70F	60 [2.362]	M5×0.8	3 [26.553]	8 [0.315]
		80 [3.150]	M6×1	5.2 [46.025]	12 [0.472]
Swing type	ECPL52S	42 [1.654]	M5×0.8	3 [26.553]	7 [0.276]
		60 [2.362]	M5×0.8	3 [26.553]	10 [0.394]
	ECPL70S	60 [2.362]	M5×0.8	3 [26.553]	8 [0.315]
		80 [3.150]	M6×1	5.2 [46.025]	12 [0.472]

Electric Compliance

Parallel type

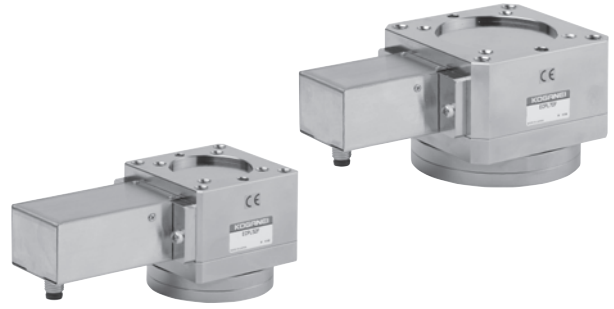

Specifications

● Parallel type

Basic type		ECPL52F	ECPL52F-N	ECPL70F	ECPL70F-N
Item					
Motor		Brushed DC motor			
Mass	g [oz]	430 [15.17]		740 [26.10]	
Operating temperature range	°C [°F]	0 to 40 [32 to 104]			
Lubrication	Sliding part	Not required			
Maximum load capacity	kg [lb]	2 [4.410]		4 [8.820]	
Movement range	X - Y	mm [in.]		±1 [0.039]	
	θ (twisting)	°		±4	
Operating time (reference value)	When locked	sec		Less than 2.0	
	When unlocked	sec		Less than 2.5	
Centripetal force (at movement range 0.5 mm [0.020 in.]) Note 1	N [lbf]	5 [1.124]	0	5 [1.124]	0
Retaining force (reference value) Note 2	N [lbf]	40 [8.992]			
Retaining moment (reference value) Note 3	N·m [in·lbf]	0.4 [3.540]		2.0 [17.702]	
Repeatability (X-Y direction) Note 4	mm [in.]	±0.05 [0.002]			
Repeatable angle accuracy (θ direction) Note 5	°	±0.5			
Withstand load	Pushing direction Note 6	N [lbf]		2840 [638.4]	
	Pulling direction Note 6	N [lbf]		1480 [332.7]	
				5150 [1158]	
				2980 [669.9]	

Note 1: Centripetal force: Indicates the force, with no load and in an unlocked state, that maintains the center position via the restraining ring.

2: Retaining force: Indicates the force that maintains the center position of the X and Y directions when locked.

3: Retaining moment: Indicates the force that maintains the center position of the θ direction when locked

4: Repeatability: The maximum deviation of the positioning accuracy at which the plate, with no load and unlocked, stops when locked after moving it in any direction.

5: Repeatable angle accuracy: The maximum deviation of the angle at which the plate, with no load and unlocked, stops when locked after rotating laterally.

6: When loads are applied, use a load of 1/10 or less of the value for the allowable load.

Remark 1: The center position when the plate is locked and the center position when it is unlocked may be misaligned.

2: Mount the product so that the center of gravity of the mounted load falls within the plate's outer diameter, and do not operate with an overhanging load.

3: The operating time changes according to the operating conditions. Consider it a reference.

4: The retaining force and retaining moment are values measured by Koganei measuring methods. Consider it a reference.

5: For the Handling Instructions and Precautions, see [page 5](#) and [6](#).

Order Codes

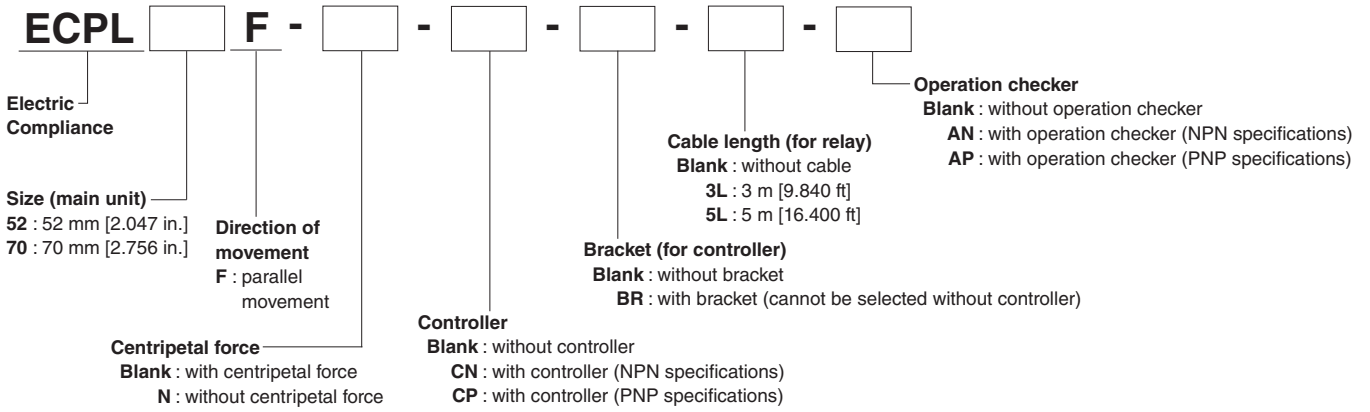

Additional parts

Controller

- [Accessories]
• Power cable
• I/O cable

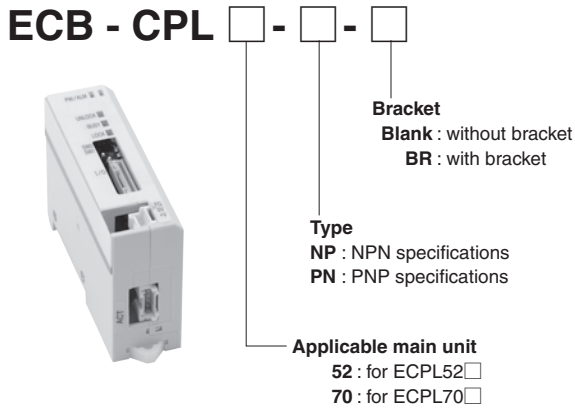

Bracket, one piece (for controller)

PSU - BR



Operation checker

- [Accessories]
• I/O cable (for operation checker only)

EAK - []



- Type**
NP : NPN specifications
PN : PNP specifications

Cable

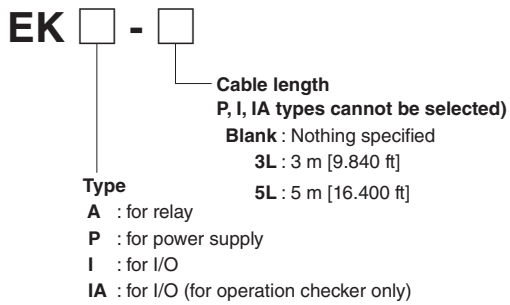

EKA- [] : for relay



EKP : for power supply



EKI : for I/O



EKIA : for I/O (for operation checker only)

ECPL52F
ECPL52F-N

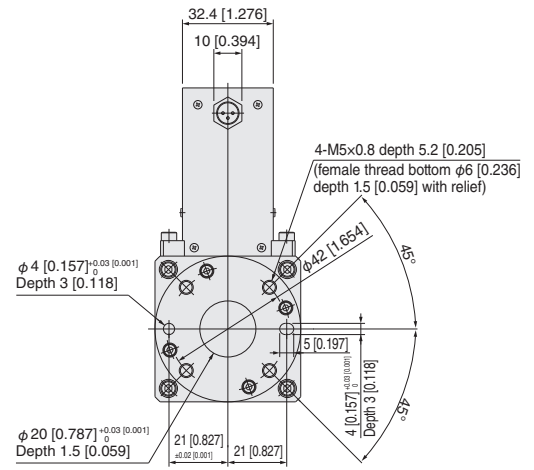
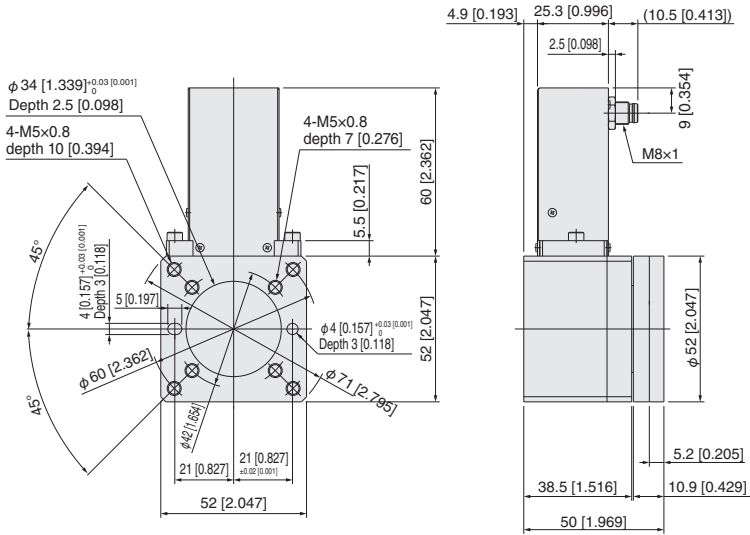
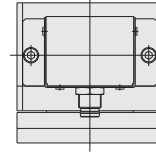
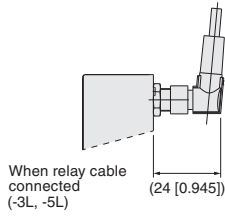

ECPL70F
ECPL70F-N

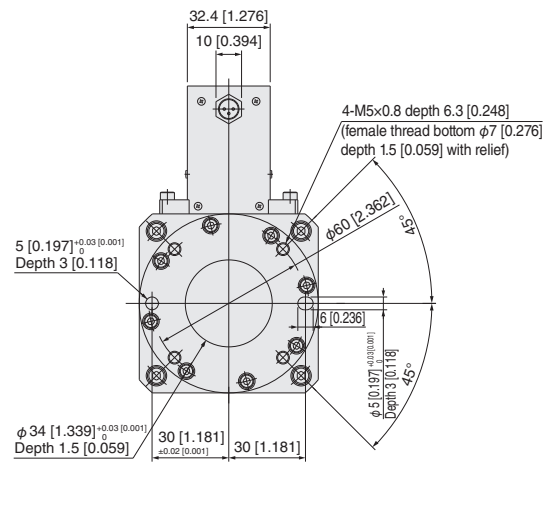
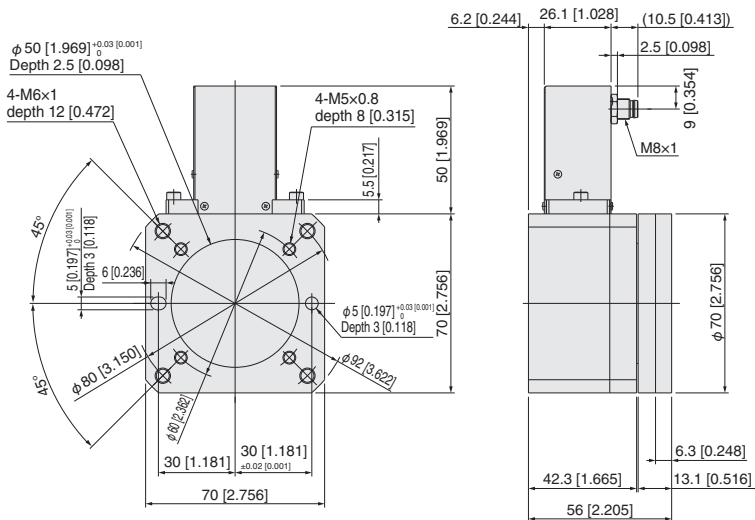
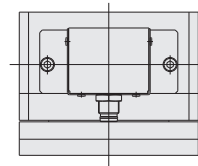
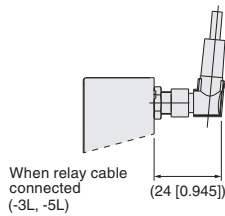

Electric Compliance

Swing type



Specifications

● Swing type

		Basic type	ECPL52S	ECPL52S-N	ECPL70S	ECPL70S-N
Item						
Motor			Brushed DC motor			
Mass	g [oz]		440 [15.52]		750 [26.46]	
Operating temperature range	°C [°F]		0 to 40 [32 to 104]			
Lubrication	Sliding part		Not required			
Maximum load capacity	kg [lb]		2 [4.410]		4 [8.820]	
Movement range	X - Y	mm [in.]	±1 [0.039]		±1.5 [0.059]	
	Z	mm [in.]	-0.5 [-0.020]		-0.7 [-0.028]	
	θ (twisting)	°	±4			
	α (Swing angle)	°	±1			
Operating time (reference value)	When locked	sec	Less than 2.0			
	When unlocked	sec	Less than 2.5			
Centripetal force (at movement range 0.5 mm [0.020 in.]) Note 1		N [lbf]	5 [1.124]	0	5 [1.124]	0
Retaining force (reference value) Note 2		N [lbf]	40 [8.992]			
Retaining moment (reference value) Note 3		N·m [in·lbf]	0.4 [3.540]		2.0 [17.702]	
Repeatability (X-Y direction) Note 4		mm [in.]	±0.05 [0.002]			
Repeatable angle accuracy (θ direction) Note 5		°	±0.5			
Withstand load	Pushing direction Note 6	N [lbf]	2840 [638.4]		5150 [1158]	
	Pulling direction Note 6	N [lbf]	1480 [332.7]		2980 [669.9]	

Note 1: Centripetal force: Indicates the force, with no load and in an unlocked state, that maintains the center position via the restraining ring.

2: Retaining force: Indicates the force that maintains the center position of the X and Y directions when locked.

3: Retaining moment: Indicates the force that maintains the center position of the θ direction when locked

4: Repeatability: The maximum deviation of the positioning accuracy at which the plate, with no load and unlocked, stops when locked after moving it in any direction.

5: Repeatable angle accuracy: The maximum deviation of the angle at which the plate, with no load and unlocked, stops when locked after rotating laterally.

6: When loads are applied, use a load of 1/10 or less of the value for the allowable load.

Remark 1: The center position when the plate is locked and the center position when it is unlocked may be misaligned.

2: Mount the product so that the center of gravity of the mounted load falls within the plate's outer diameter, and do not operate with an overhanging load.

3: The operating time changes according to the operating conditions. Consider it a reference.

4: The retaining force and retaining moment are values measured by Koganei measuring methods. Consider it a reference.

5: For the Handling Instructions and Precautions, see [page 5](#) and [6](#).

Order Codes

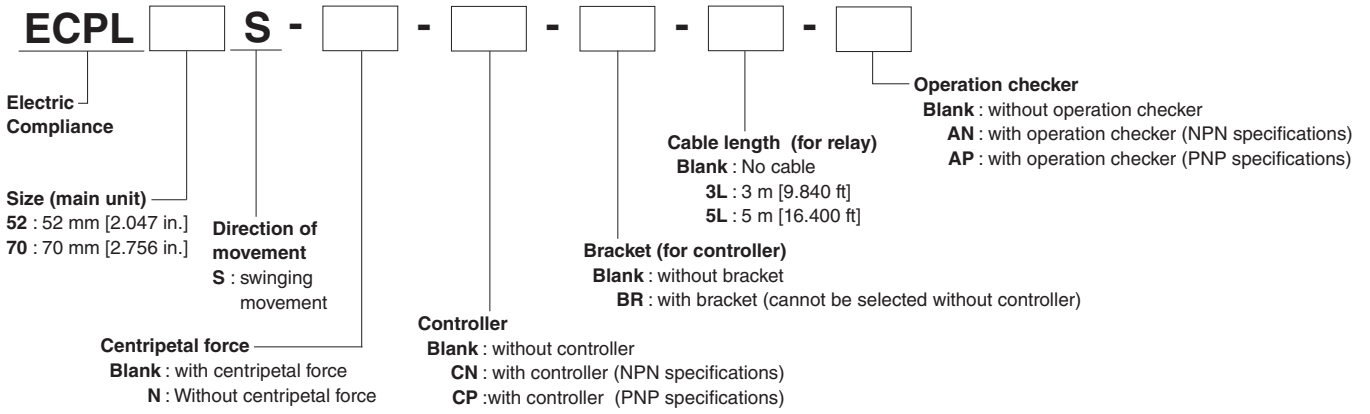

Additional parts

Controller

- [Accessories]
• Power cable
• I/O cable

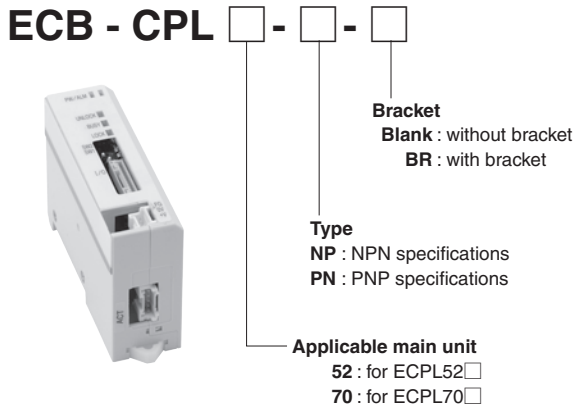

Bracket, one piece (for controller)

PSU - BR



Operation checker

- [Accessories]
• I/O cable (for operation checker only)

EAK - []



Type
NP : NPN specifications
PN : PNP specifications

Cable

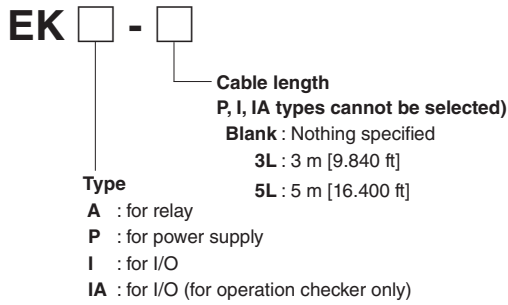

EKA- : for relay



EKP: for power supply



EKI: for I/O



EKIA: for I/O (for operation checker only)

ECPL52S ECPL52S-N

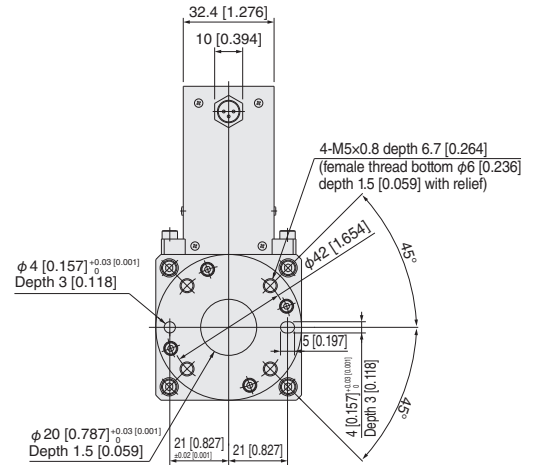
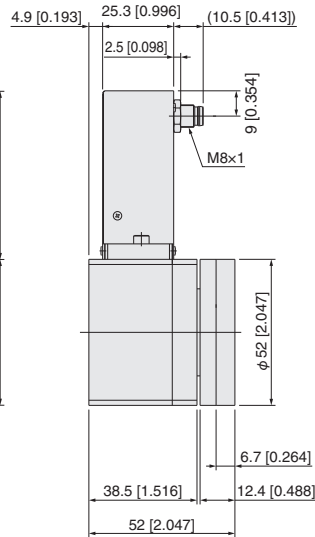
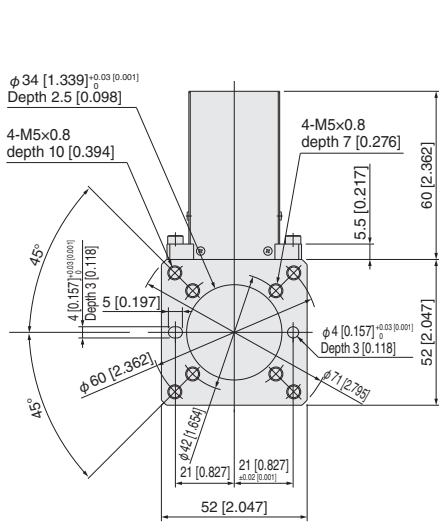
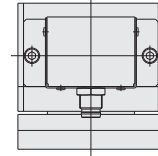
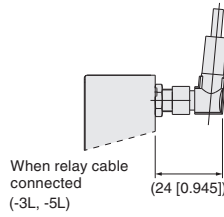

ECPL70S ECPL70S-N

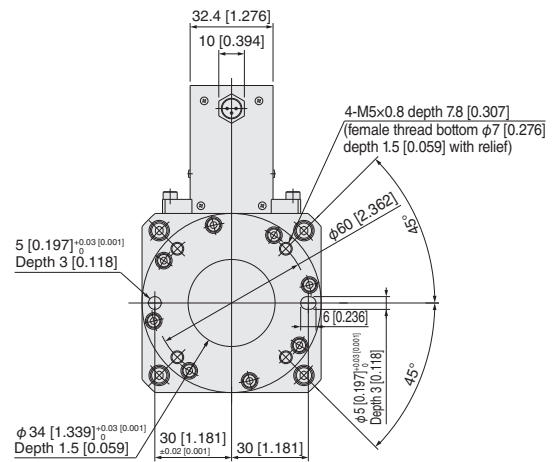
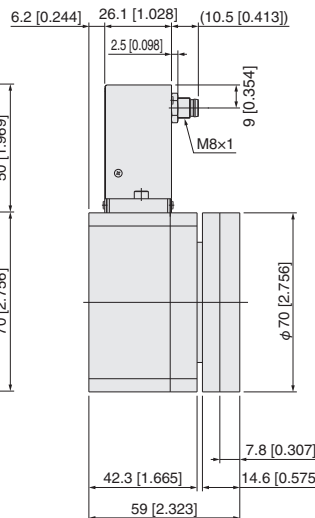
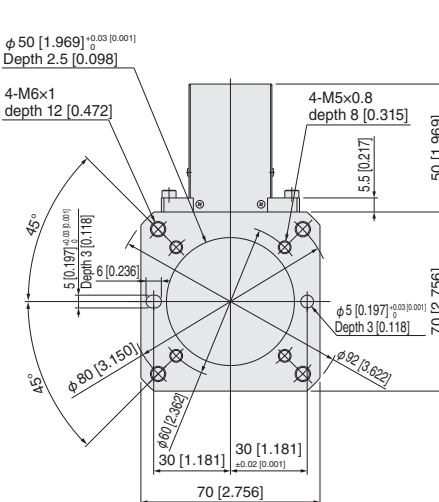
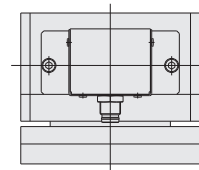
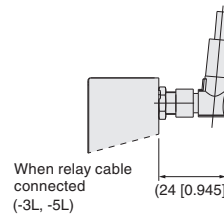

Combination of Electric Compliance and Electric Auto Hand Changer

● This is an example of direct installation of an Electric Compliance and an Electric Auto Hand Changer.

Electric Compliance Plate mounted

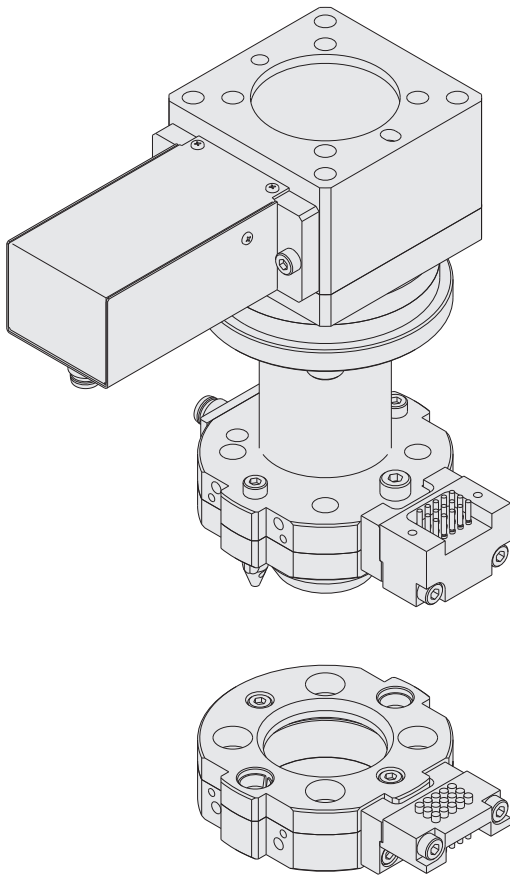

Electric Compliance Main unit mounted

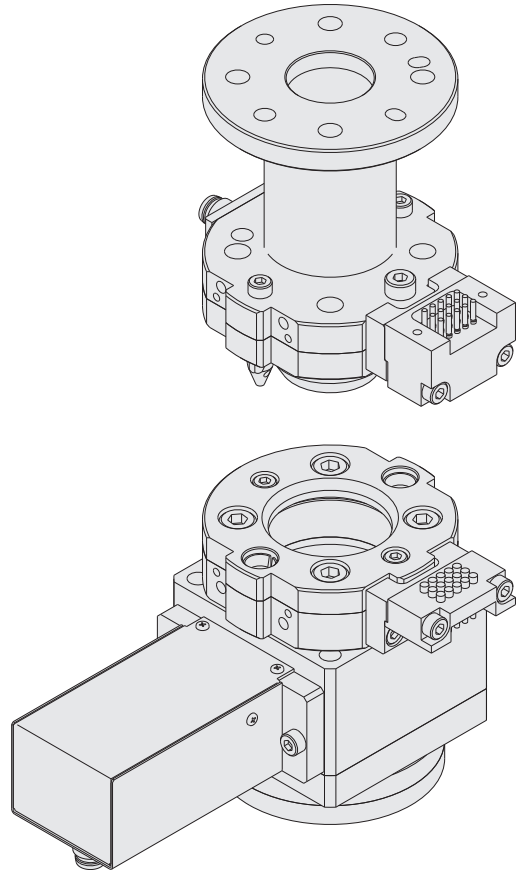

An Electric Compliance and an Electric Auto Hand Changer can be (directly) installed.

Electric Compliance	Electric Auto Hand Changer	
	EMJ3T ^{Note}	EMJ10T ^{Note}
ECPL52□ Main unit side	○	△
ECPL70□ Main unit side	—	○

○ : Direct installation possible (using bolts and positioning pins)

△ : Installation with bolts is possible, positioning pins cannot be used.

— : Direct installation is not possible

Note : Direct installation is not possible when non-contact electrodes are selected for the Electric Auto Hand Changer.

Electric Compliance	Electric Auto Hand Changer	
	EMJ3M	EMJ10M
ECPL52□ Plate side	○	—
ECPL70□ Plate side	—	○

○ : Direct installation possible (using bolts and positioning pins)

— : Direct installation is not possible

*The bolts and positioning pins must be provided by the customer.

Controller

NPN specifications



Specifications

Item	Model	ECB-CPL□-NP
Control method	Motor drive system	Square-wave drive
	Control method	Current control method
	End detection method	Current detection method
	Number of points	2 points (both ends)
	Control input	2 points (ILK, IULK)
	Control output	3 points (OLK, OULK, ALARM)
	Error detection output	Disconnect, abnormal temperature, abnormal voltage, idling
	Relay cable	Cable specifically for motor drive output
	Sensor cable	None
General specifications	Mass	40 g [1.41 oz]
	Power supply	24 VDC ±10% 1.0 A MAX
	Power supply indication	+V / 0V / F.G.
	Operating temperature range	0 to 40°C [32 to 104°F]
	Operating humidity range	35 to 85% RH (no condensation)
	Operating temperature range	-10 to 65°C [14 to 149°F]
	Compatible standards	CE Marking
	Accessories	I/O cable, power cable Mounting bracket (when -BR is selected)
	Installation method	Direct installation (M2.6×0.45 depth 5 [0.197], 2 places), DIN rail installation, using mounting bracket

Controller wiring method

1. When the controller's internal power supply is used

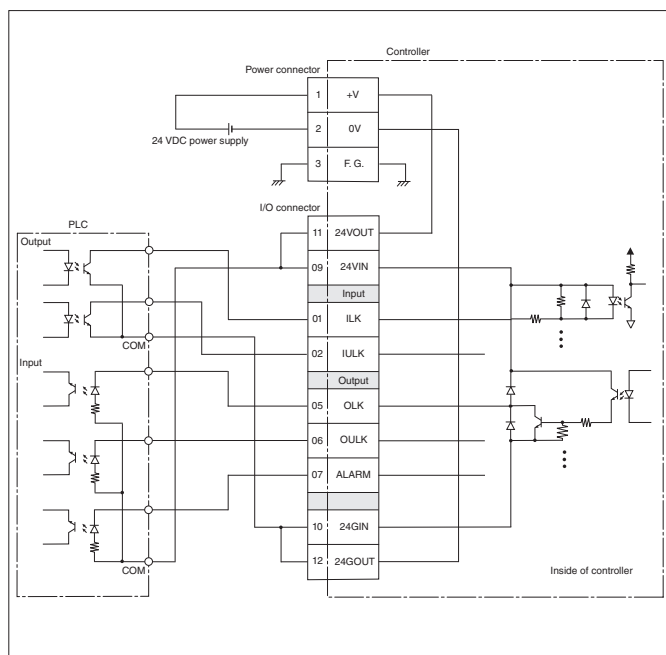

*Short-circuit 09-11 and 10-12 even if input or output only.

2. When using a power supply that is separate from the internal power supply of the controller

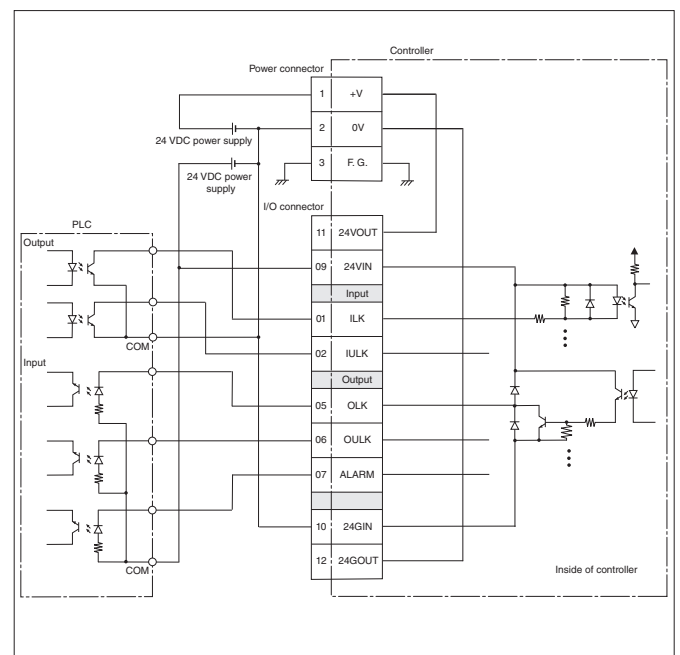

*Connect power supply to 09 and 10 even if input or output only.

Controller

PNP specifications



Specifications

Item	Model	ECB-CPL□-PN
Control method	Motor drive system	Square-wave drive
	Control method	Current control method
	End detection method	Current detection method
	Number of points	2 points (both ends)
	Control input	2 points (ILK, IULK)
	Control output	3 points (OLK, OULK, ALARM)
	Error detection output	Disconnect, abnormal temperature, abnormal voltage, idling
	Relay cable	Cable specifically for motor drive output
	Sensor cable	None
General specifications	Mass	40 g [1.41 oz]
	Power supply	24 VDC ±10% 1.0 A MAX
	Power supply indication	+V / 0V / F.G.
	Operating temperature range	0 to 40°C [32 to 104°F]
	Operating humidity range	35 to 85% RH (no condensation)
	Operating temperature range	-10 to 65°C [14 to 149°F]
	Compatible standards	CE Marking
	Accessories	I/O cable, power cable Mounting bracket (when -BR is selected)
	Installation method	Direct installation (M2.6×0.45 depth 5 [0.197], 2 places), DIN rail installation, using mounting bracket

Controller wiring method

1. When the controller's internal power supply is used

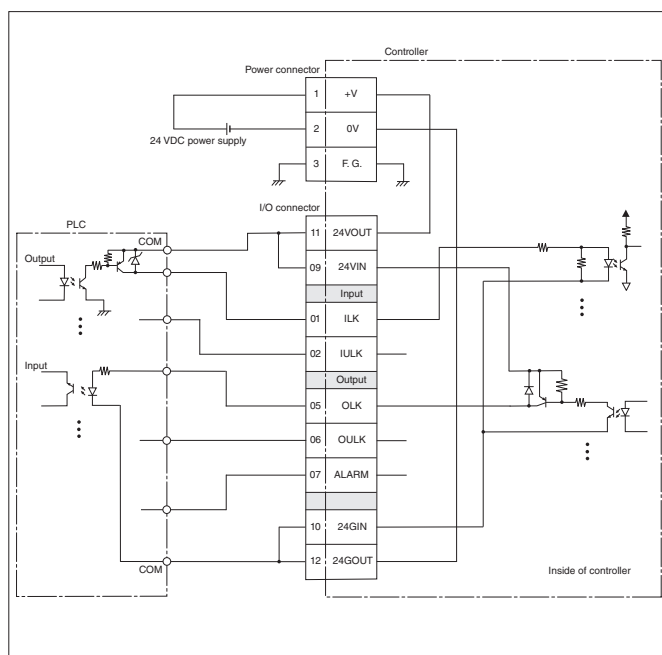

*Short-circuit 09-11 and 10-12 even if input or output only.

2. When using a power supply that is separate from the internal power supply of the controller

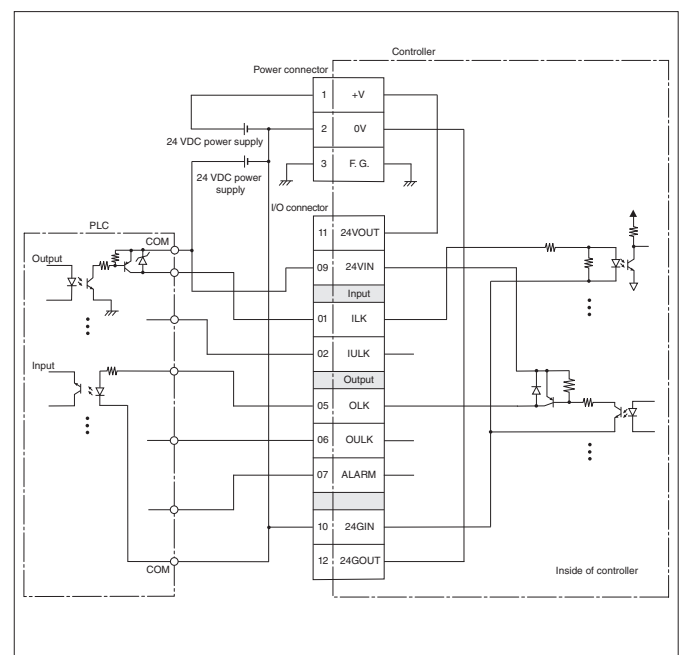

*Connect power supply to 09 and 10 even if input or output only.

Dimensions (mm [in.])

● Controller

ECB - CPL - -

Bracket
Blank : None
BR : with bracket

Type
NP : NPN specifications
PN : PNP specifications

Applicable main unit
52 : for ECPL52□
70 : for ECPL70□

Electric Compliance Controller

*Accessories: Power cable, I/O cable

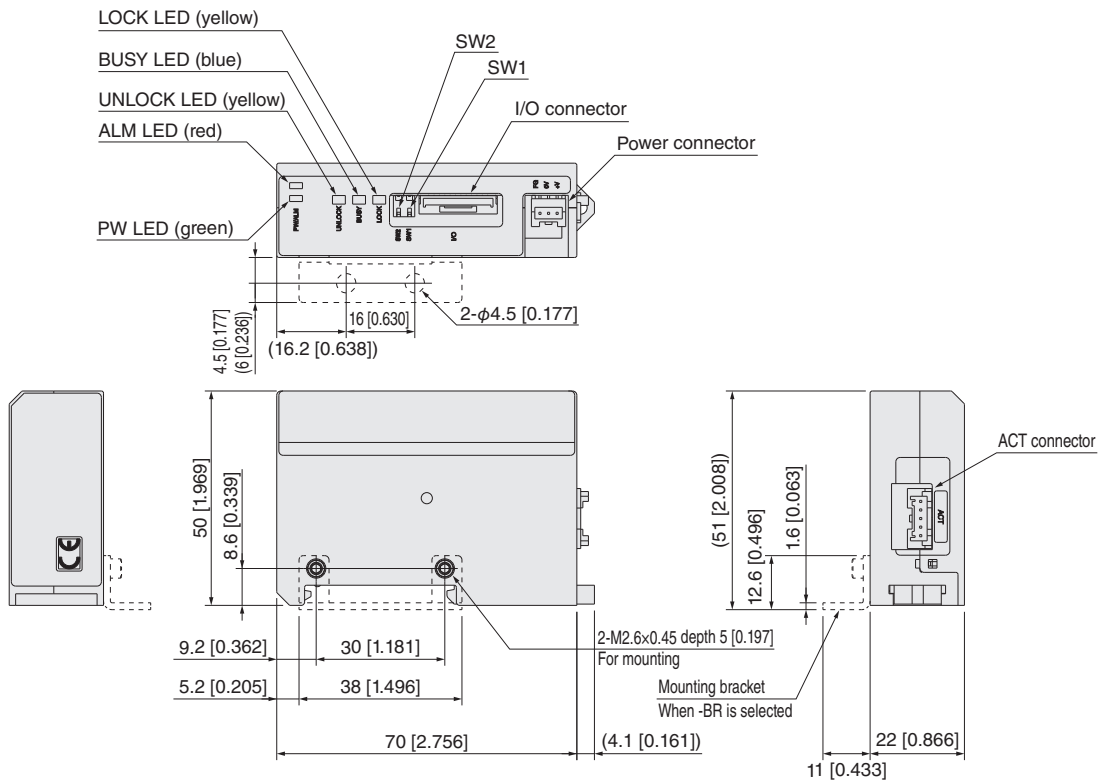

*The dotted lines are the bracket dimensions.

Dimensions (mm [in.])

● Cables

• For relay

EKA-

3L: 3 m [9.840 ft]
5L: 5 m [16.400 ft]

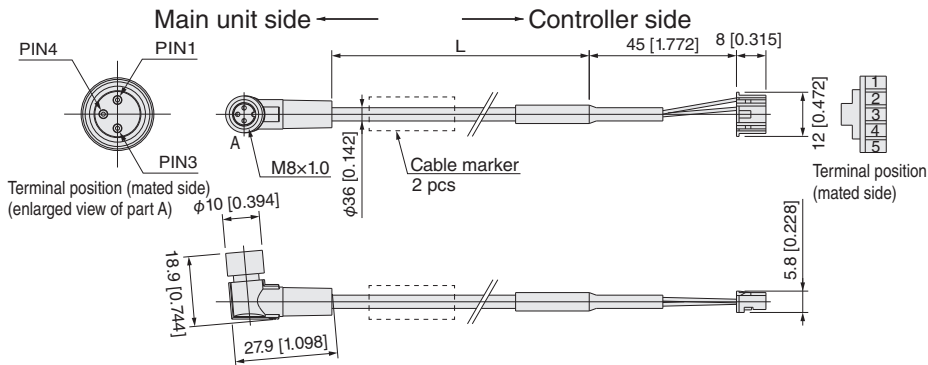

Main unit side connector

PIN	Name	Color
1	+M	Brown
3	-M	Blue
4	N.C.	Black

Controller side connector

No.	Name	Color
1	+M	Brown
2	-M	Blue
3	SEN1	-
4	SEN2	-
5	SENG	-

Model	L
EKA-3L	3 m [9.840 ft]
EKA-5L	5 m [16.400 ft]

• For power supply

EKP

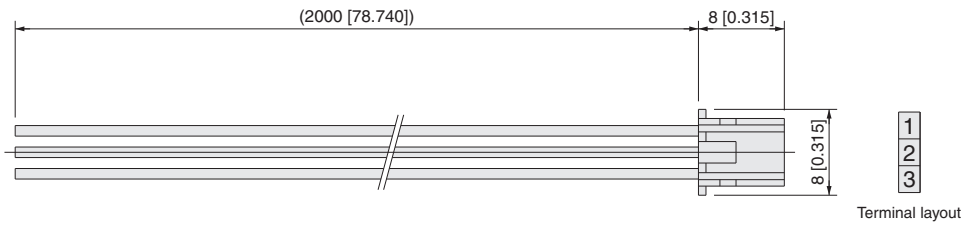

Power connector terminal layout

NO.	Name	Color
1	24V	Red
2	GND	Blue
3	F.G.	Green

Terminal layout

• For I/O

EKI

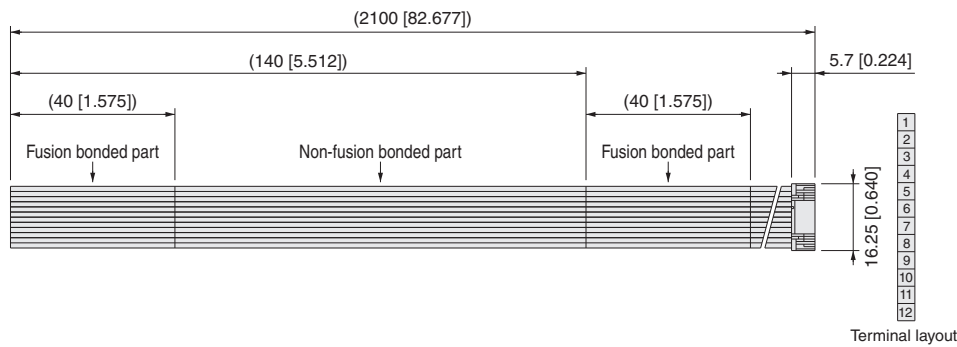

I/O connector terminal layout

NO.	Color
1	Brown
2	Red
3	Orange
4	Yellow
5	Green
6	Blue
7	Purple
8	Gray
9	White
10	Black
11	Brown
12	Red

Terminal layout

• For I/O (for operation checker only)

EKIA

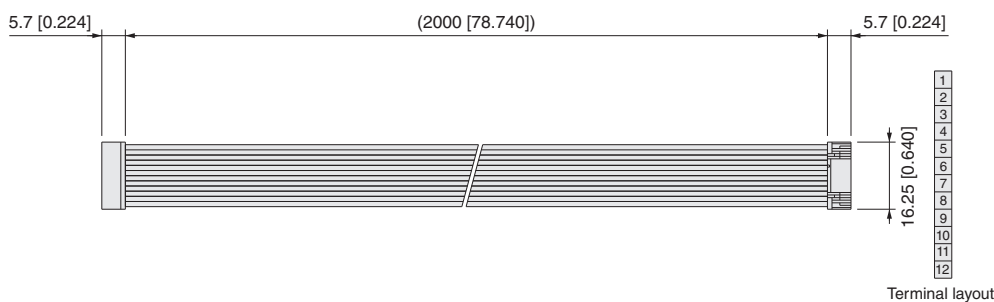

I/O connector terminal layout

NO.	Color
1	Brown
2	Red
3	Orange
4	Yellow
5	Green
6	Blue
7	Purple
8	Gray
9	White
10	Black
11	Brown
12	Red

Terminal layout

Selection guidelines

● Electric Compliance System Configuration Diagrams (Examples)

● NPN specifications

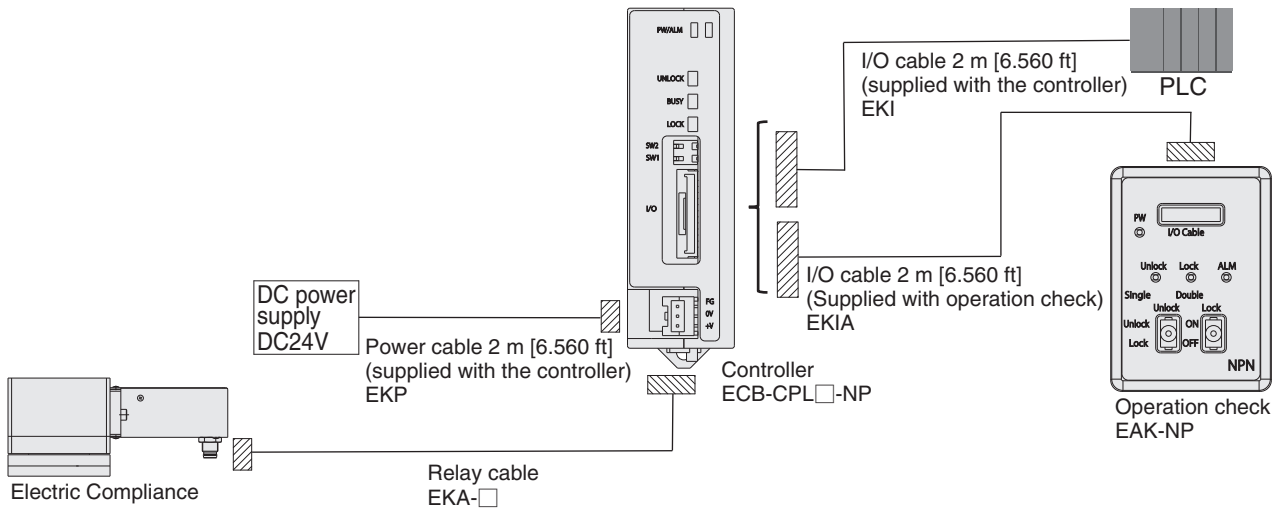

● PNP specifications

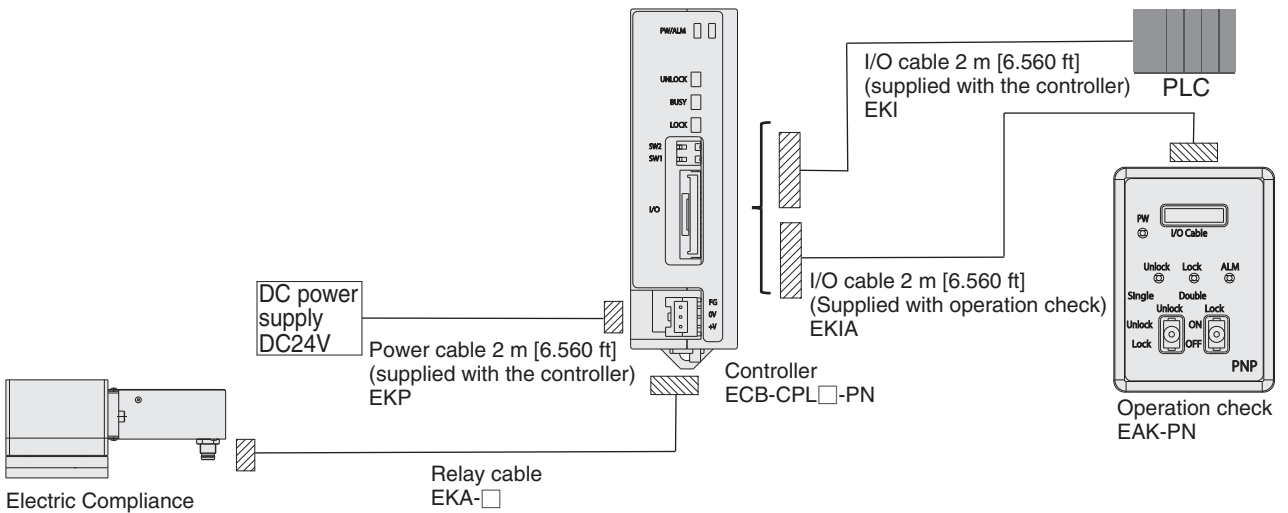

Operation checker

NPN specifications • PNP specifications



Specifications

Item	Model	EAK-NP	EAK-PN
Control method	Control input	3 points (InLock, InUnlock, InALM)	
	Control output	2 points (OutLock, OutUnlock)	
General specifications	Mass	40 g [1.41 oz]	
	Power supply voltage	Supplied from controller 24 VDC	
	Consumption current	50 mA MAX	
	Power supply indication	LED lit when power turned on	
	Operating temperature range	0 to 40°C [32 to 104°F]	
	Operating humidity range	35 to 85% RH (no condensation)	
	Operating temperature range	-10 to 65°C [14 to 149°F]	
	Accessories	I/O cable	
Applicable controller models		ECB-□-NP	ECB-□-PN

Operation checker dimensions (mm [in.])

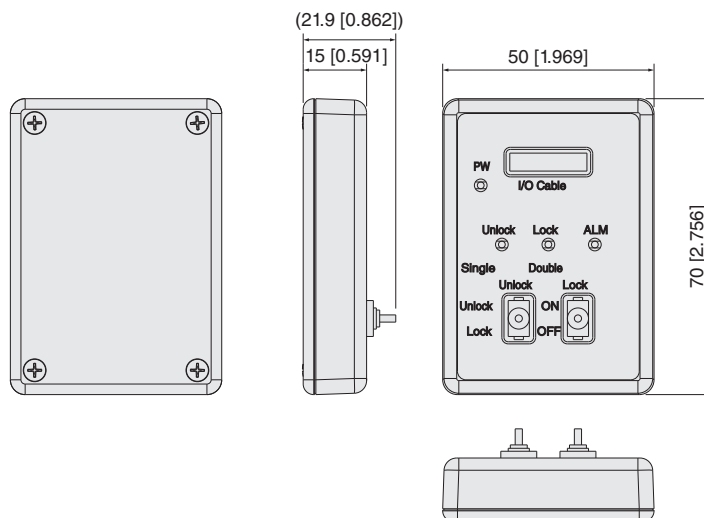
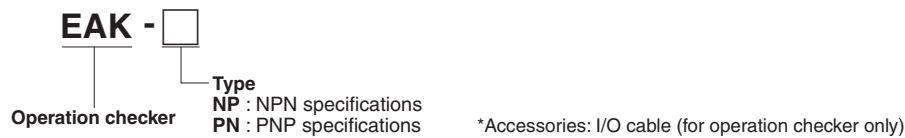

Limited Warranty

KOGANEI CORP. warrants its products to be free from defects in material and workmanship subject to the following provisions.

Warranty Period The warranty period is 180 days from the date of delivery.

Koganei Responsibility If a defect in material or workmanship is found during the warranty period, KOGANEI CORP. will replace any part proved defective under normal use free of charge and will provide the service necessary to replace such a part.

Limitations

- This warranty is in lieu of all other warranties, expressed or implied, and is limited to the original cost of the product and shall not include any transportation fee, the cost of installation or any liability for direct, indirect or consequential damage or delay resulting from the defects.

- KOGANEI CORP. shall in no way be liable or responsible for injuries or damage to persons or property arising out of the use or operation of the manufacturer's product.

- This warranty shall be void if the engineered safety devices are removed, made inoperative or not periodically checked for proper functioning.

- Any operation beyond the rated capacity, any improper use or application, or any improper installation of the product, or any substitution upon it with parts not furnished or approved by KOGANEI CORP., shall void this warranty.

- This warranty covers only such items supplied by KOGANEI CORP. The products of other manufacturers are covered only by such warranties made by those original manufacturers, even though such items may have been included as the components.

The specifications are subject to change without notice.

URL: <http://www.koganeiusa.com>

E-mail: sales@koganeiusa.com



KOGANEI CORPORATION

OVERSEAS DEPARTMENT

3-11-28, Midori-cho, Koganei City, Tokyo 184-8533, Japan
Tel: (+81)42-383-7271 Fax: (+81)42-383-7276

KOGANEI INTERNATIONAL AMERICA, INC.

48860 Milmont Drive, Suite 108C, Fremont, California 94538
Tel: 1-510-744-1626 Fax: 1-510-744-1676

SHANGHAI KOGANEI INTERNATIONAL TRADING CORPORATION

RM2601-2602, Tongda Venture Building No.1, Lane 600, Tianshan Road,
Shanghai, China (200051)
Tel: 86-21-6145-7313 Fax: 86-21-6145-7323

TAIWAN KOGANEI TRADING CO., LTD

Rm. 2, 16F., No88, Sec. 2, Zhongxiao E. Rd., Zhongzheng Dist., Taipei City 100,
Taiwan(ROC)
Tel: 886-2-2393-2717 Fax: 886-2-2393-2719

KOGANEI KOREA CO., LTD

A-3001, Heungdeok IT Valley Bldg., Heungkeok 1-ro, 13, Giheung-gu, Yongin-si, Gyeonggi-do,
446-908, KOREA
Tel: 82-31-246-0414 Fax: 82-31-246-0415

KOGANEI (THAILAND) CO., LTD

555, Rasa Tower 1, 11th Fl., Unit 1107 and 1108, Phaholyothin Road, Chatuchak,
Chatuchak, Bangkok 10900
Tel: +66 (0) 2513-1228-31 Fax: +66 (0) 2513-1232

KOGANEI AUTOMATION (MALAYSIA) SDN, BHD.

Suite 29-2, Level 29, Menara 1MK, No.1, Jalan Kiara, Mont Kiara
50480, Kuala Lumpur, Malaysia
Tel: 60-12-537-7086

KOGANEI ASIA PTE. LTD.

69 Ubi Road 1, #05-18 Oxley Bizhub Singapore 408731
Tel: 65-6293-4512 Fax: 65-6293-4513